



PROFESSIONAL DIGITAL TWO-WAY RADIO

MOTOTRBO™ MOBILE DM 3000/4000 SERIES INSTALLATION GUIDE



Foreword

This manual is intended for use by experienced technicians familiar with similar types of equipment. Specifically, it contains installation information required for the MOTOTRBO Series Mobile Radios.

For information related to the service of the MOTOTRBO Series Mobile Radios, refer to *Related Publications on page v* for the list of applicable manuals available separately. Product Safety and RF Exposure Compliance

See *Installation Requirements for Compliance with Radio Frequency (RF) Energy Exposure Safety Standards* on page ii.

Computer Software Copyrights

The Motorola products described in this manual may include copyrighted Motorola computer programs stored in semiconductor memories or other media. Laws in the United States and other countries preserve for Motorola certain exclusive rights for copyrighted computer programs, including, but not limited to, the exclusive right to copy or reproduce in any form the copyrighted computer program. Accordingly, any copyrighted Motorola computer programs contained in the Motorola products described in this manual may not be copied, reproduced, modified, reverse-engineered, or distributed in any manner without the express written permission of Motorola. Furthermore, the purchase of Motorola products shall not be deemed to grant either directly or by implication, estoppel, or otherwise, any license under the copyrights, patents or patent applications of Motorola, except for the normal non-exclusive license to use that arises by operation of law in the sale of a product.

Document Copyrights

No duplication or distribution of this document or any portion thereof shall take place without the express written permission of Motorola. No part of this manual may be reproduced, distributed, or transmitted in any form or by any means, electronic or mechanical, for any purpose without the express written permission of Motorola.

Disclaimer

The information in this document is carefully examined, and is believed to be entirely reliable. However, no responsibility is assumed for inaccuracies. Furthermore, Motorola reserves the right to make changes to any products herein to improve readability, function, or design. Motorola does not assume any liability arising out of the applications or use of any product or circuit described herein; nor does it cover any license under its patent rights nor the rights of others.

Trademarks

MOTOROLA, MOTO, MOTOROLA SOLUTIONS and the Stylized M logo are trademarks or registered trademarks of Motorola Trademark Holdings, LLC and are used under license. All other trademarks are the property of their respective owners.

© 2006 – 2011 Motorola Solutions, Inc. All rights reserved.

Installation Requirements for Compliance with Radio Frequency (RF) Energy Exposure Safety Standards

ATTENTION!

This radio is intended for use in occupational/controlled conditions, where users have full knowledge of their exposure and can exercise control over their exposure to meet FCC limits. This radio device is NOT authorized for general population, consumer, or any other use.

To ensure compliance to RF Energy Safety Standards:

- Install only Motorola approved antennas and accessories.
- Be sure that antenna installation is per *Antenna Installation* on page 2-11 of this manual.
- Be sure that Product Safety and RF Safety Booklet enclosed with this radio is available to the end user upon completion of the installation of this radio.

Before using this product, the operator must be familiar with the RF energy awareness information and operating instructions in the Product Safety and RF Exposure booklet enclosed with each radio (Motorola publication part number 6866537D37) to ensure compliance with Radio Frequency (RF) energy exposure limits.



For radios installed in vehicles fuelled by liquefied petroleum gas, refer to the (U.S.) National Fire Protection Association standard, NFPA58, for storage, handling, and/or container information.

This radio has a transmitter Time-out Timer that disables the transmitter during a transmission after a pre-defined time period, which by default is set to 60 seconds.



It is recommended NOT to change the default 60 seconds time period for the Time-out Timer as the radio is intended for intermittent duty cycle operation.

For a list of Motorola-approved antennas and other accessories, visit the following web site, which lists approved accessories for your radio model:

<http://www.motorolasolutions.com/governmentandenterprise>

Table of Contents

Foreword	i
Computer Software Copyrights	i
Document Copyrights	i
Disclaimer	i
Trademarks	i
Installation Requirements for Compliance with Radio Frequency (RF) Energy Exposure Safety Standards	ii
Mobile Radio Model Numbering Scheme	vi
Chapter 1 Introduction	1-1
1.1 Mobile Radio Description	1-1
1.1.1 Dimensions	1-1
1.1.2 Connections on the Back of the Radio	1-3
1.2 Standard Configurations	1-4
1.2.1 Dash Mount Configuration	1-4
1.2.2 Remote Mount Configuration (DM 3000 Series Mobiles only)	1-4
1.2.3 Base/Control Stations	1-5
Chapter 2 Installation Details for Standard Configurations	2-1
2.1 Planning the Installation	2-1
2.1.1 Tools Required for Installation	2-1
2.1.2 Installation Example	2-1
2.1.3 Wiring Diagrams	2-2
2.2 Radio Mounting	2-4
2.2.1 Dash Mount with Trunnion	2-5
2.2.2 Locking Kit (Optional)	2-6
2.2.2.1 All Radios	2-6
2.2.3 DIN Mount	2-6
2.2.3.1 To install the frame into the dashboard	2-6
2.2.3.2 To Mount the radio in the frame	2-7
2.2.3.3 To Remove the radio from the frame	2-8
2.2.4 Remote Mount with Trunnion	2-8
2.3 Power Cable	2-8
2.4 Ignition Sense Cable	2-11
2.5 Antenna Installation	2-11
2.5.1 Selecting an Antenna Site/Location on a Metal Body Vehicle	2-11
2.5.2 Antenna Installation Procedure	2-12
2.5.3 Antenna Connection	2-13
2.6 Microphone Hang-Up Clip	2-13
2.6.1 Standard Hang-Up Clip	2-13
2.7 Completing the Installation	2-13
Chapter 3 Options and Accessories Installation	3-1
3.1 Accessory Installation	3-1
3.1.1 Emergency Pushbutton or Footswitch Installation	3-3
3.1.2 Horn and Lights (External Alarm) Relay	3-4
3.1.3 External Speaker	3-5

Chapter 4	Best Practices: Installation & Troubleshooting.....	4-1
4.1	Check Wiring of Ignition and Radio Ignition Sensing.....	4-1
4.2	Check Physical Installation of Radio Ground and Radio Accessory Wiring.....	4-2
4.3	Improve the Electrical Quality of the Power and Ignition Lines.....	4-2
4.4	Jump-Start the Vehicle	4-3
4.5	Eliminate Noise/Howling from PA Speaker.....	4-3
Appendix A	EMEA Regional Warranty, Service and Technical Support	A-1
A.1	Warranty and Service Support.....	A-1
A.1.1	Warranty Period and Return Instructions.....	A-1
A.1.2	After Warranty Period	A-1
A.2	European Radio Support Centre (ERSC)	A-2
A.3	Piece Parts	A-2
A.4	Technical Support.....	A-3
A.5	Further Assistance From Motorola	A-3
Index	Index-1

List of Figures

Figure 1-1	Front View of Dash Mount Trunnion for MOTOTRBO DM 3000 Series.....	1-1
Figure 1-3	Side View of Dash Mount with Low Profile Trunnion for MOTOTRBO DM 3000 Series.....	1-2
Figure 1-2	Front View of Dash Mount Trunnion for MOTOTRBO DM4000 Series.....	1-2
Figure 1-4	Side View of Dash Mount with Low Profile Trunnion for MOTOTRBO DM4000 Series.....	1-3
Figure 1-5	Back View of the Mobile Radio	1-3
Figure 1-6	Dash Mount Configuration	1-4
Figure 1-7	Example of a Base/Control Station Configuration.....	1-5
Figure 2-1	Typical Dash Mount Configuration	2-1
Figure 2-2	Typical Remote Mount Configurations	2-2
Figure 2-3	Radio Installation (Dash Mount).....	2-2
Figure 2-4	Radio Installation (Remote Mount)	2-3
Figure 2-5	Trunnion Orientation for Above or Below Mobile	2-4
Figure 2-6	Transmission Hump Trunnion Mounting	2-5
Figure 2-7	Below Dash Trunnion Mounting.....	2-5
Figure 2-8	Locking Kit (Optional).....	2-6
Figure 2-9	Dashboard Mounting for MOTOTRBO DM 3000 Series.....	2-7
Figure 2-10	Dashboard Mounting for MOTOTRBO DM4000 Series.....	2-7
Figure 2-11	Cabling Interconnect Diagram for Dash Mount.....	2-9
Figure 2-12	Cabling Interconnect Diagram for Remote Mount.....	2-10
Figure 2-13	Antenna connections on the back of the radio.....	2-12
Figure 2-14	BNC/Mini-UHF Connection	2-13
Figure 3-1	Location of the Rear Accessory Connector	3-1
Figure 3-2	Pin Configuration of Rear Accessory Connector (as viewed from the rear of the radio)	3-2
Figure 3-3	Emergency Switch Wiring Diagram	3-3
Figure 3-4	Horn and Lights Wiring Diagram.....	3-4
Figure 3-5	External Speaker Mounting.....	3-5

Related Publications

MOTOTRBO DM 3000 Series Mobile Basic Service Manual	6866575D33
MOTOTRBO DM4000 Series Mobile Basic Service Manual	68012003037

Mobile Radio Model Numbering Scheme

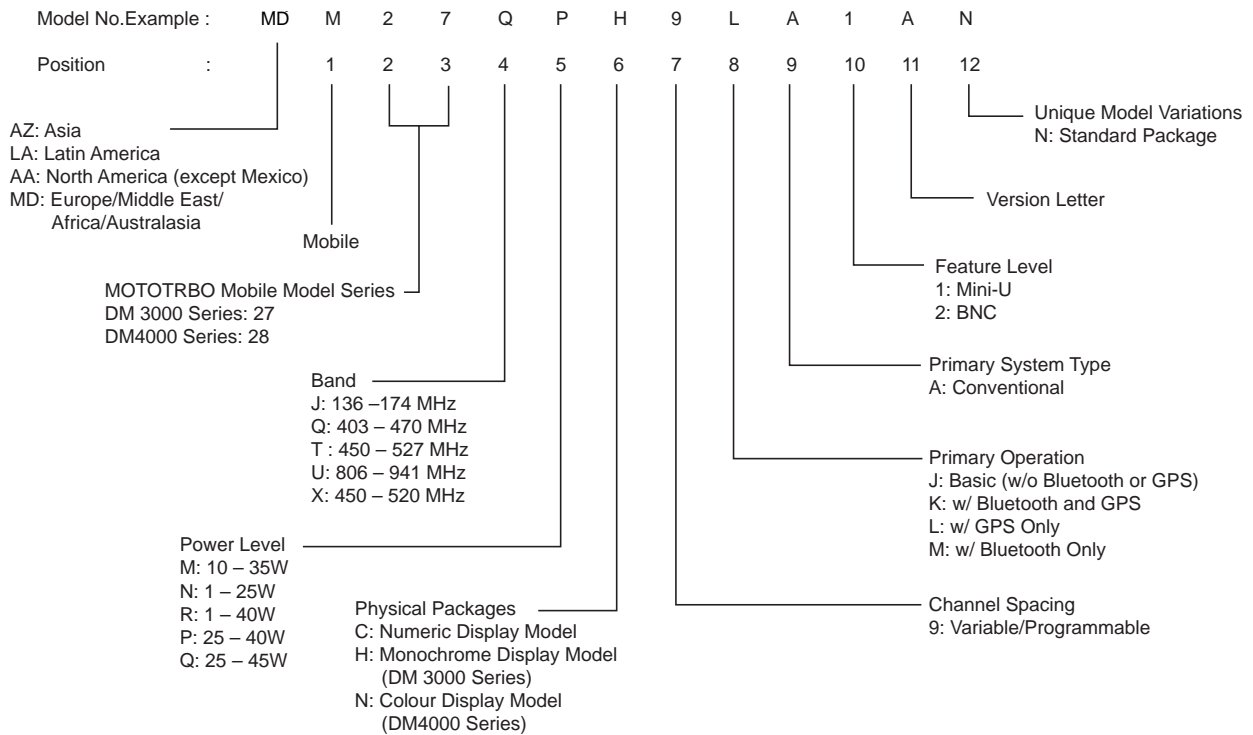

Chapter 1 Introduction

This manual covers the installation procedures for MOTOTRBO Series Digital Mobile Radios and accessories required to complete the radio system. The radio system consists of a control head, radio, antenna, microphone, speaker, cabling, and accessories.

1.1 Mobile Radio Description

1.1.1 Dimensions

Figure 1-1, Figure 1-2, Figure 1-3 and Figure 1-4 show the basic dimensions of the dash mount trunnion of the mobile radio.

When installing the radio, make sure to plan the installation carefully and leave additional room in the rear of the radio for cabling and accessory connections; in the front of the radio for access, controls, and cabling; and to the sides of the radio so that you may access and install the trunnion wing screws.

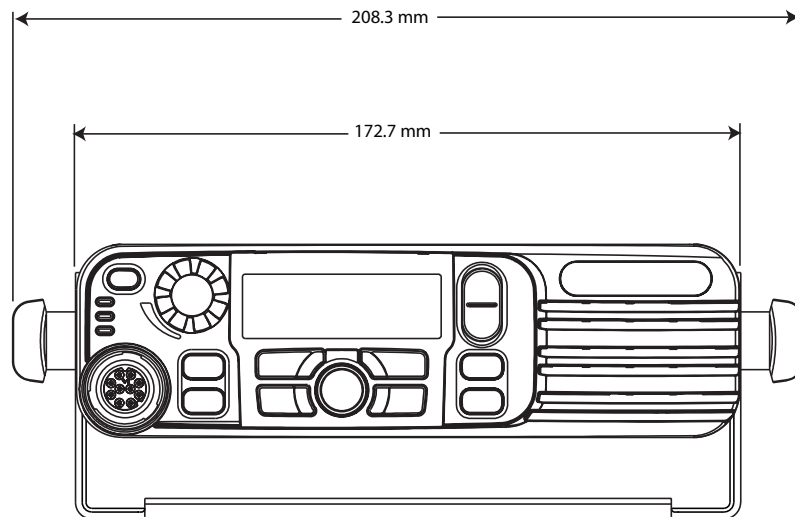

Figure 1-1 Front View of Dash Mount Trunnion for MOTOTRBO DM 3000 Series

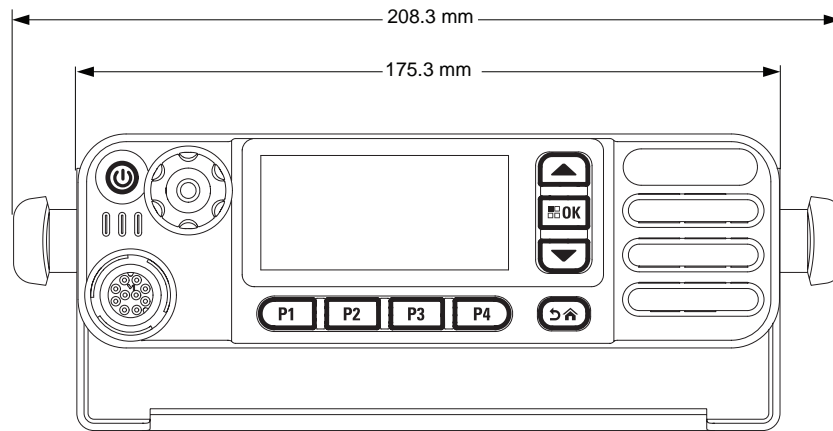

Figure 1-2 Front View of Dash Mount Trunnion for MOTOTRBO DM4000 Series

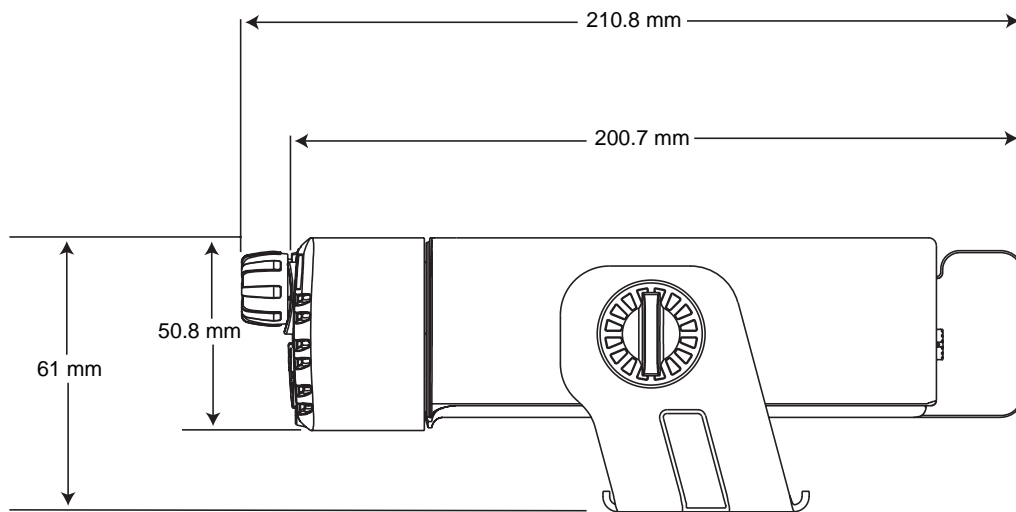

Figure 1-3 Side View of Dash Mount with Low Profile Trunnion for MOTOTRBO DM 3000 Series

NOTE: The MOTOTRBO DM 3000 Series mobile models use wing screws with thread length of 14.9 mm while the DM4000 Series mobile models require wing screws with thread length of 9.9 mm to secure the radio to the mounting trunnion.

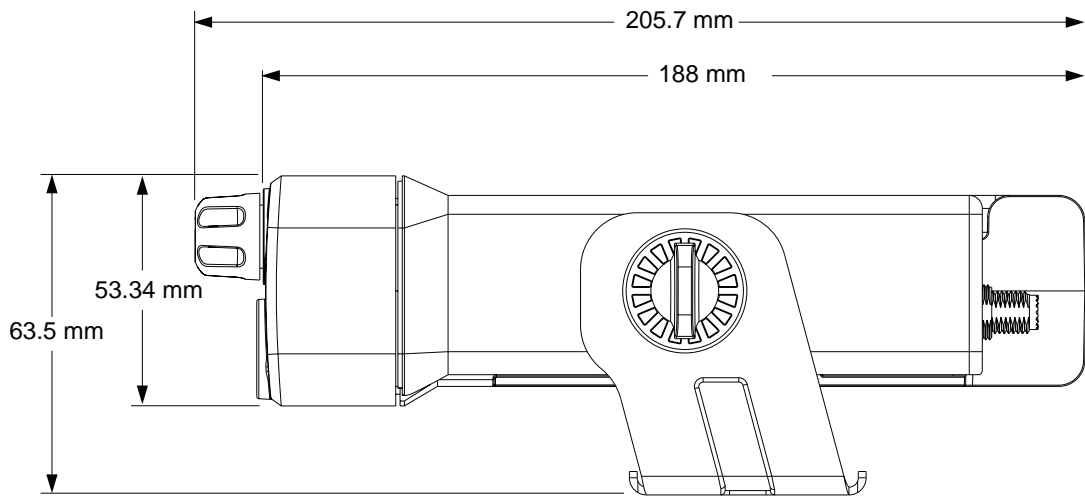

Figure 1-4 Side View of Dash Mount with Low Profile Trunnion for MOTOTRBO DM4000 Series

NOTE: The rear accessory connector adds 19.1 mm to the overall length.

1.1.2 Connections on the Back of the Radio

Figure 1-5 shows the connections that are found on the back of the radio.

For complete pin configuration of the rear accessory connector, see Figure 3-2 on page 3-2.

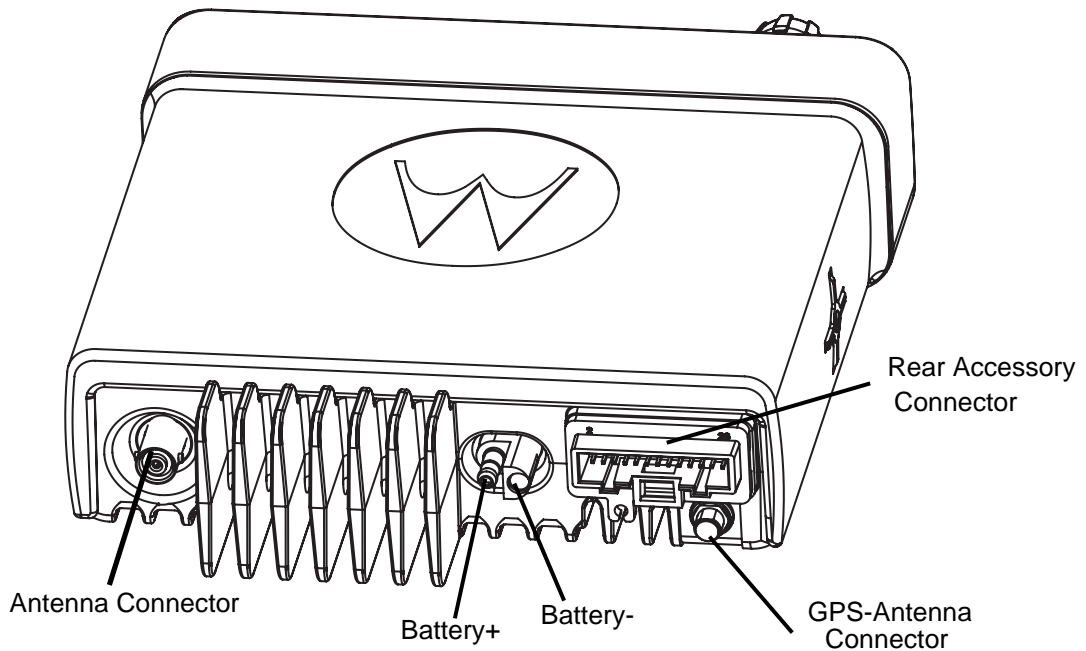

Figure 1-5 Back View of the Mobile Radio

1.2 Standard Configurations

The DM 3000 Series mobile can be either dash mounted or remote mounted. The DM4000 Series mobile can only be dash mounted at this time.

1.2.1 Dash Mount Configuration

In the dash mount configuration of the mobile radio, the control head is mounted on the front of the transceiver housing. Electrical connection between the two takes place within the radio via a flexible cable between the connectors on the front of the transceiver and at the back of the control head.

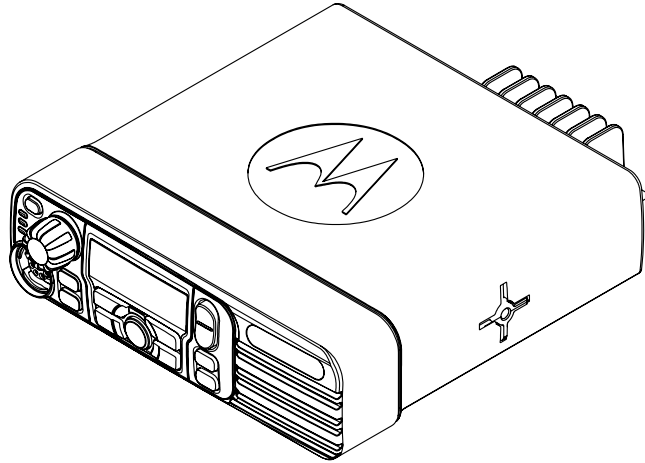

Figure 1-6 Dash Mount Configuration

For details on this configuration, see [Section 2.2.1 on page 2-5](#).

1.2.2 Remote Mount Configuration (DM 3000 Series Mobiles only)

In the remote control version, the control head and the transceiver are mounted separately in the vehicle. The control head is mounted in a remote trunnion (PMLN4912_) near the operator using an extension cable. The transceiver is mounted using one of the trunnion mounting options shown in [Table 2-1 on page 2-4](#). If the transceiver is located in a car trunk, be sure that secure mounting and sufficient cooling are provided. Do not cover the transceiver with baggage, blankets, etc.

See publication 6878397A01 for the MOTOTRBO DM 3000 Series mobile radio remote mount control head installation instructions.

1.2.3 Base/Control Stations

If the mobile radio equipment is installed at a fixed location and operated as a control station or as a fixed unit, the radio and antenna installation must comply with the following requirements in order to ensure optimal performance and compliance with the RF energy exposure limits in the standards and guidelines listed in the Safety Booklet (Motorola publication part number 6866537D37) provided with the radio:



Caution

For outdoor antenna installations, proper site grounding and lightning protection are vitally important. Failure to provide proper lightning protection may result in permanent damage to the radio equipment. Refer to Motorola Quality Standards Fixed Network Equipment Installation Manual R56 (which can be obtained by ordering CDROM 9880384V83) for complete information regarding lightning protection.

- The antenna should be mounted outside the building on the roof or a tower if at all possible and the antenna cable should be earth grounded.
- The radio chassis must be earth grounded and a lightning surge protector, PolyPhaser ISB50LN-C2-MA (Motorola part number DSISB50LNC2MA) or equivalent, should be used in line with the radio connector and the outdoor antenna. The lightning surge protector should be earth grounded and located at the point where the antenna cable enters the building.
- The line voltage power supply must have a proper ground connection (refer to IEC61312-1).
- As with all fixed site antenna installations, it is the responsibility of the licensee to manage the site in accordance with applicable regulatory requirements, such as EMC (Electromagnetic Compatibility) and IEC (International Electrotechnical Commission). Also, additional compliance actions such as site survey measurements, signage, and site access restrictions may be required in order to ensure that exposure limits are not exceeded.

NOTE: The GPN6145B power supply is only approved for Base/Control Station operation with the 1-25 watt DM 3000 Series mobile radios. The HPN4007D power supply is approved for Base/Control Station operation for all DM 3000 Series and DM4000 Series mobile radios.

Figure 1-7 shows a typical setup of a Base/Control Station configuration.

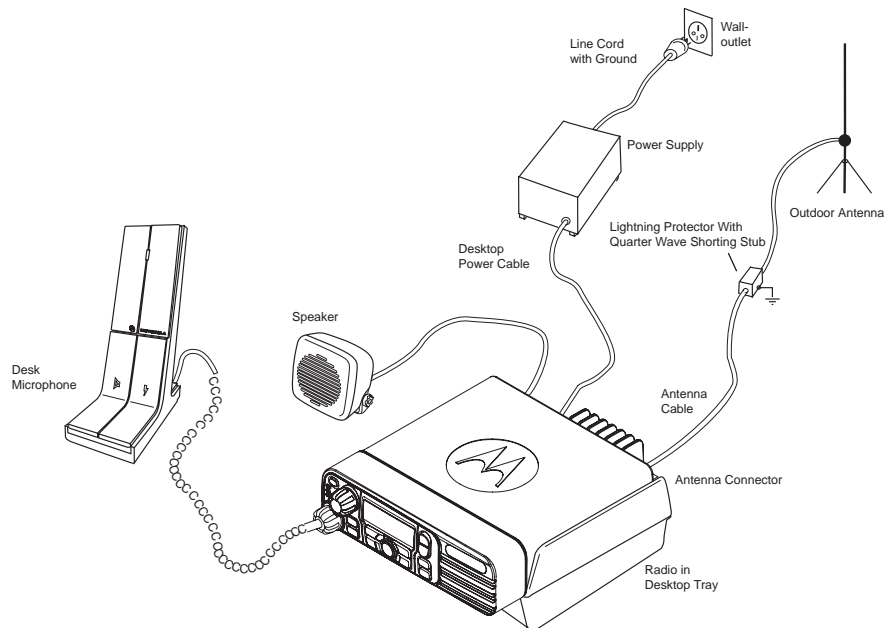

Figure 1-7 Example of a Base/Control Station Configuration

Notes

Chapter 2 Installation Details for Standard Configurations

2.1 Planning the Installation

The mobile radio operates only in negative ground electrical systems. Before starting the radio installation, make sure that the ground polarity of the vehicle is correct. Accidentally reversing the polarity will not damage the radio, but will cause the cable fuses to blow.

Planning is the key to fast, easy radio installation. Before starting the installation, inspect the vehicle and determine how and where you intend to mount the antenna, radio, and accessories. Plan wire and cable runs to provide maximum protection from pinching, crushing, and overheating.



Before installing any electrical equipment, check the vehicle manufacturer's user manual. The installation of this device should be completed by an authorized servicer or installer.

2.1.1 Tools Required for Installation

Tool	Motorola Part Number
11/32 hex driver	—
Rubber-coated pliers	—
Regular slot screwdriver or Phillips #2	—
Pin removal tool	6680163F01
1/4 hex driver	—

2.1.2 Installation Example

The mobile two-way radio offers various methods of installation, with accessories placed to the vehicle as desired. The radio can be a dash or remote mount (DM4000 Series mobile can only be dash mounted) (see [Figure 2-1](#) and [Figure 2-2](#)).

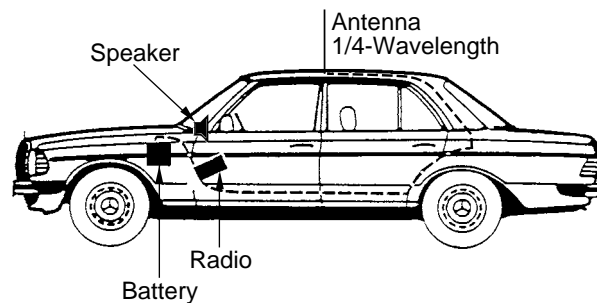

Figure 2-1 Typical Dash Mount Configuration

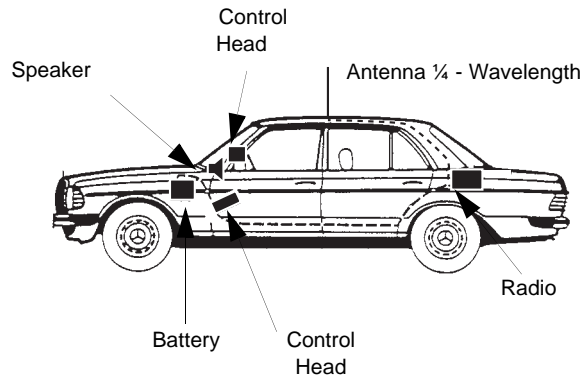

Figure 2-2 Typical Remote Mount Configurations

2.1.3 Wiring Diagrams

Figure 2-3 shows the wiring diagrams for some of the possible configurations. Identify the configuration that you are installing, and use the diagram when planning the installation.

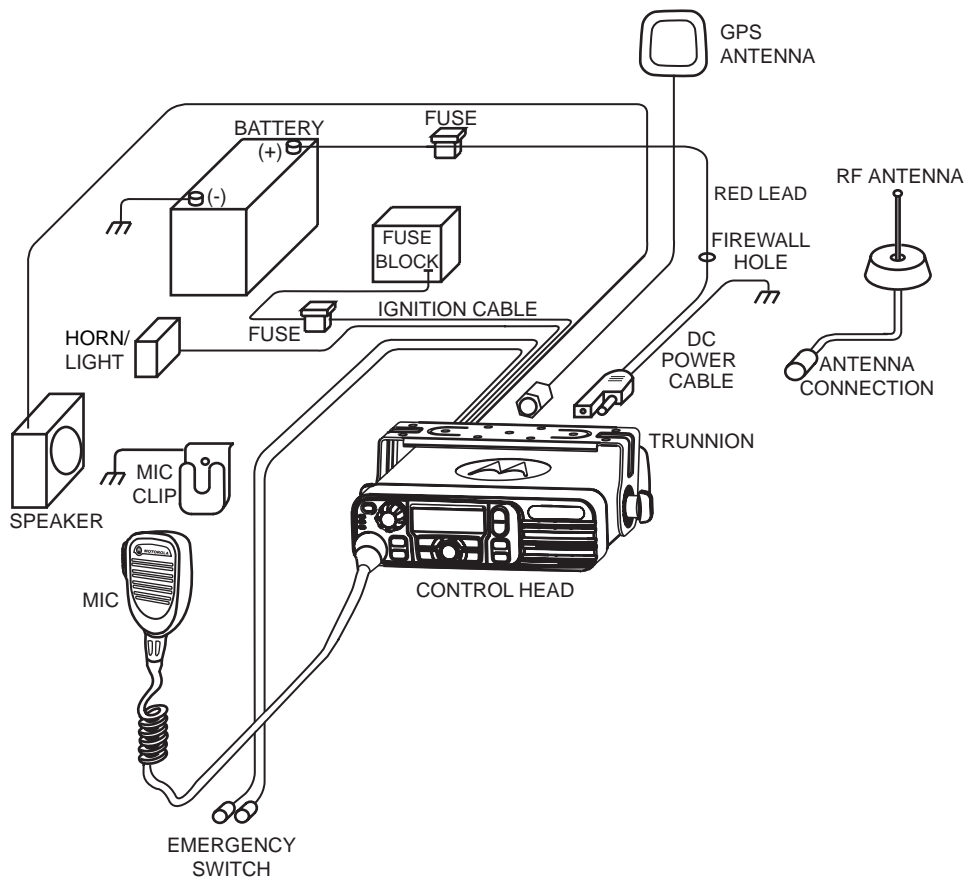

Figure 2-3 Radio Installation (Dash Mount)

(For complete rear accessory connector pin configuration, see [Figure 3-2.](#))

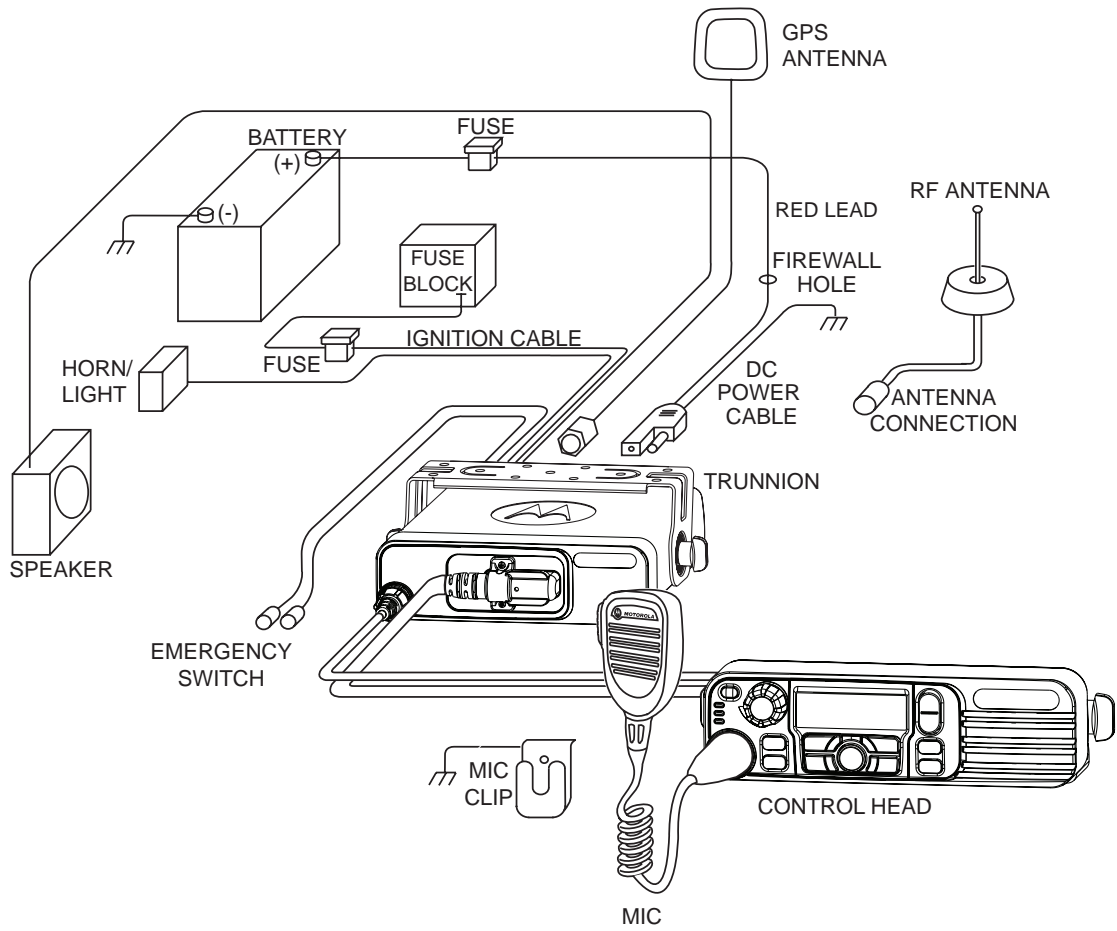

Figure 2-4 Radio Installation (Remote Mount)

2.2 Radio Mounting



DO NOT mount the radio on a plastic dashboard without first reinforcing the dashboard; the weight of the radio may crack or break the dashboard.



DO NOT mount the radio on a flat or concave surface where the radio could be partially submerged in water. This is especially important if the cab area of the vehicle is cleaned by spraying with water. If the radio sits in water for a length of time, moisture may seep inside the radio and damage the electronic components.



DO NOT allow water to stand in recessed areas of vertically mounted radios. Remove any moisture immediately to prevent it from seeping down into the radio.

The mounting location must be accessible and visible. Select a location that will permit routing the RF antenna cable as directly as possible.

For new or existing installations, use one of the mounting kits as specified in [Table 2-1](#). Orient the mounting trunnion as shown in [Figure 2-5](#).

Table 2-1. Mounting Kits

Mounting Kit	Motorola Part Number for DM 3000 Series	Motorola Part Number for DM4000 Series
Low Profile Trunnion Kit (ships as part of mobile radio package)	RLN6076_	RLN6469_
Low Profile Trunnion Kit (ships in a box – intended for resale)	RLN6077_	RLN6466_
Standard Profile Trunnion Kit	RLN6078_	RLN6467_
Key Lock Trunnion Kit	RLN6079_	RLN6468_
DIN Mount Kit	RLN5933_	RLN6465_

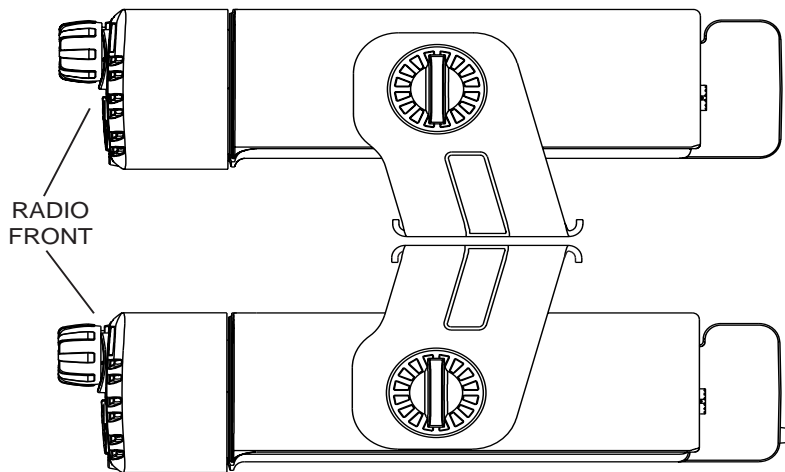

Figure 2-5 Trunnion Orientation for Above or Below Mobile

2.2.1 Dash Mount with Trunnion

1. Select the location to mount your radio on the transmission hump (see [Figure 2-6](#)) or under the dash (see [Figure 2-7](#)). When mounting the trunnion on the transmission hump take care the transmission housing is not affected.
2. Using the trunnion mounting bracket as a template, mark the positions of the holes on the mounting surface. Use the innermost four holes for a curved mounting surface such as the transmission hump, and the four outermost holes for a flat surface such as under the dash.
3. Center punch the spots you have marked and realign the trunnion in position.
4. Secure the trunnion mounting bracket with the self-drilling screws provided. The number of screws used will depend on how the radio is mounted (see [Figure 2-6](#) and [Figure 2-7](#)).
5. Position the radio to align the trunnion with the trunnion mounting features on the radio (see [Figure 2-6](#)). Secure the radio with the two wing screws and lock washers (position the flat side of the washer to the thumbscrew and the washer sharp side to the trunnion) provided.

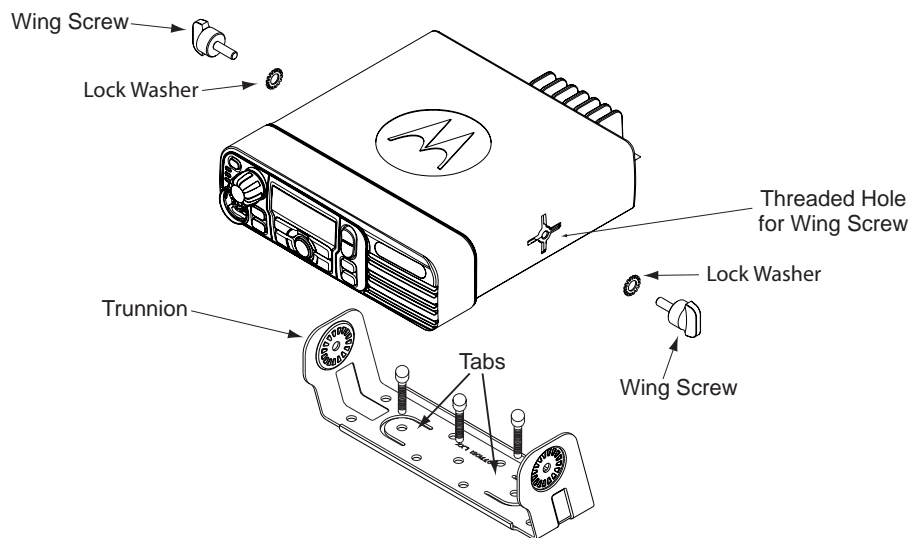

Figure 2-6 Transmission Hump Trunnion Mounting

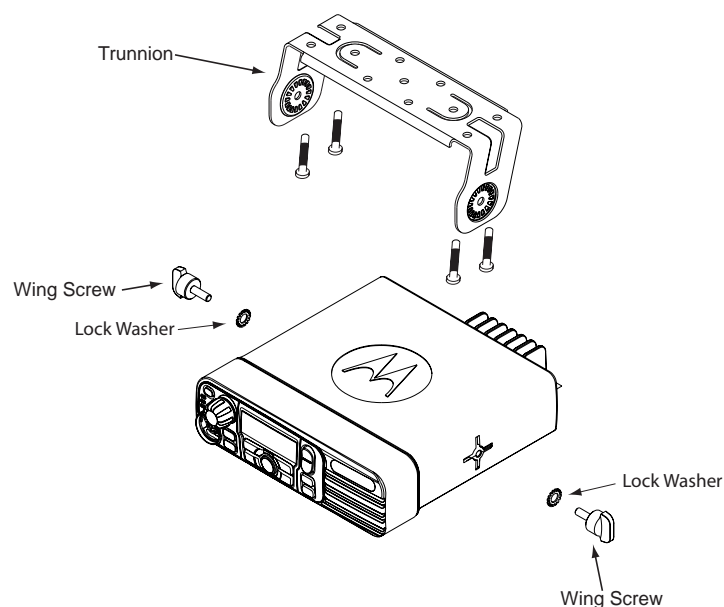

Figure 2-7 Below Dash Trunnion Mounting

2.2.2 Locking Kit (Optional)

2.2.2.1 All Radios

If an optional locking kit is used (shown in [Figure 2-8](#)), position the lock bottom housing on the trunnion before installing the radio mounting screws. Then slip the top lock housing on and remove the key. You can install the lock on either side of the radio.

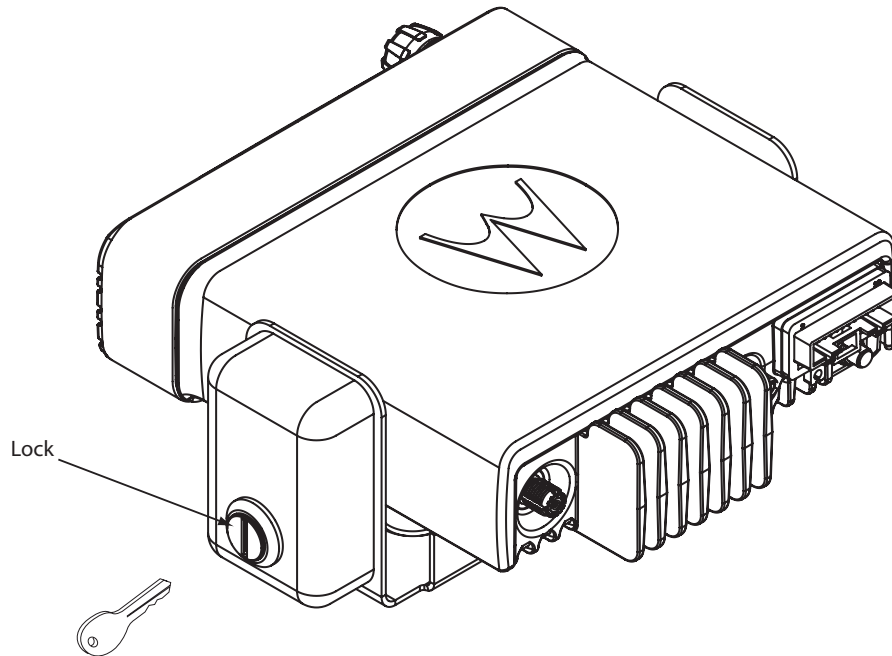

Figure 2-8 Locking Kit (Optional)

2.2.3 DIN Mount

2.2.3.1 To install the frame into the dashboard

1. Open up the radio cut-out in the dashboard to ISO7736 specification (182 mm x 53 mm).
2. Insert the mounting frame into the cut-out and retain it by bending back the relevant fixing tabs (using all 6 where possible). Check the orientation of the frame is correct by ensuring that the word "TOP" is uppermost.

NOTE: The tabs are easily bent back by twisting a large flat-head screwdriver in the slot behind the tabs.

NOTE: For a more secure installation the frame should also be secured with the appropriate number of screws to the mounting conditions (min. 1).

NOTE: The demounting tool can be used as an aid to mounting as well as demounting.

2.2.3.2 To Mount the radio in the frame

1. Provide the electrical connections for the radio (power, antenna, accessories).
2. Plug in all the connectors and push the radio firmly into the mounting frame until the two springs snap into place (see [Figure 2-9](#) and [Figure 2-10](#)).

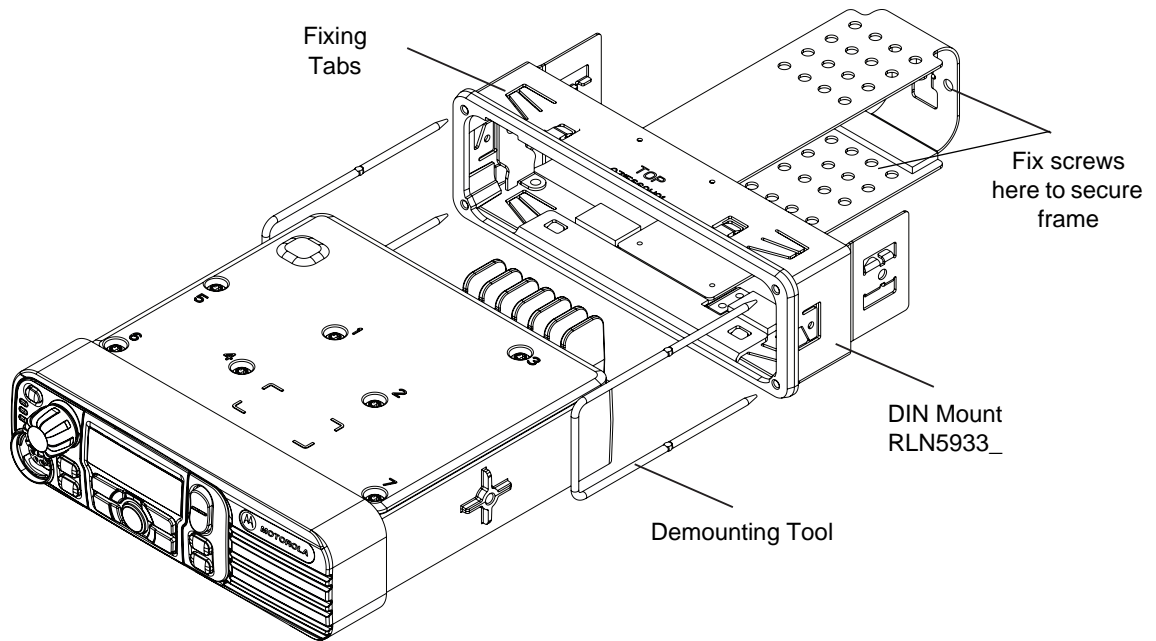

Figure 2-9 Dashboard Mounting for MOTOTRBO DM 3000 Series

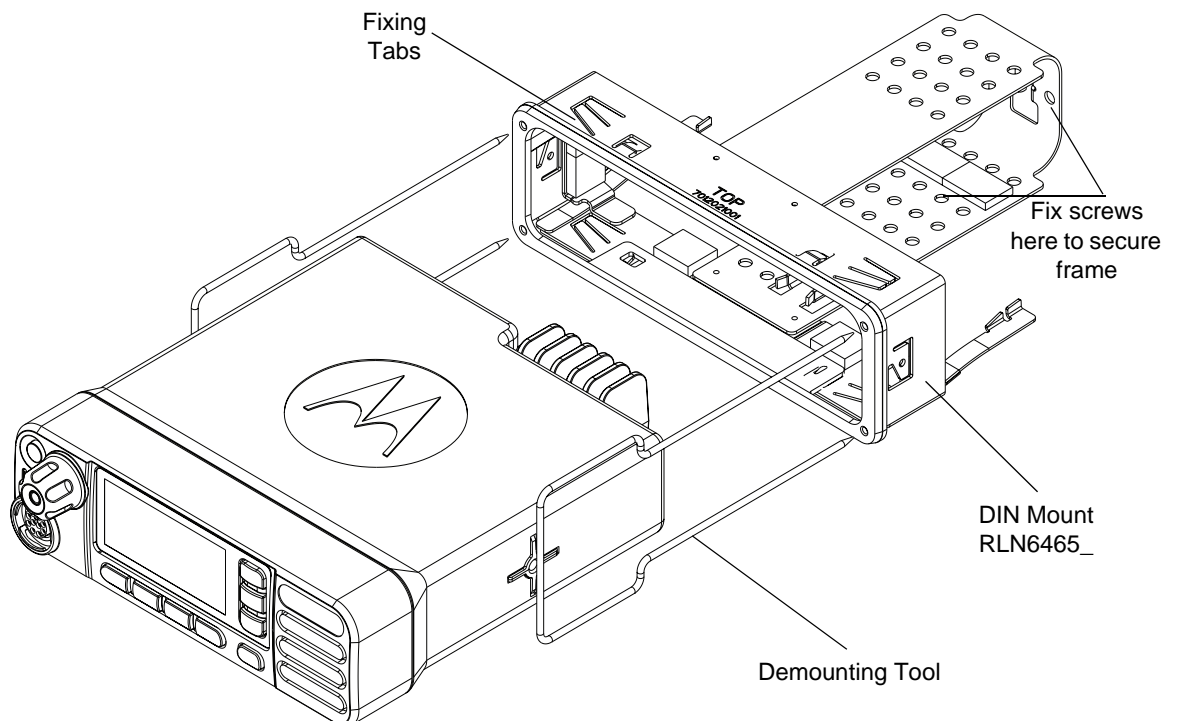

Figure 2-10 Dashboard Mounting for MOTOTRBO DM4000 Series

2.2.3.3 To Remove the radio from the frame

1. Push the two demounting tools through the openings in the frame until the two springs release the radio.
2. Slide out the radio.

NOTE: The fixing tabs should be checked for tightness each time the radio is removed. The tabs are easily tightened by twisting a large flat-head screwdriver in the slot behind the tabs.

NOTE: The frame is not designed for regular mounting and demounting.

2.2.4 Remote Mount with Trunnion



Caution

Before installing any electrical equipment, check the vehicle manufacturer's user manual.

The installation of this device should be completed by an authorized servicer or installer.

Before making any holes in the trunk for radio mounting, check the vehicle manufacturer's user manual for restrictions (e.g. due to the gas tank location).

For a remote mount installation, the transceiver may be mounted anywhere in the vehicle, provided that the installation location is safe, follows the cautions mentioned at the beginning of this section, and is accessible for servicing/maintenance as well as cabling. A typical mounting location recommended by Motorola is the vehicle's trunk. The trunnion provided may still be used to mount the transceiver, and the mounting process is the same as for the dash mount installation.

See publication 6878397A01 for the MOTOTRBO DM 3000 Series mobile radio remote mount control head installation instructions.

2.3 Power Cable

Route the red radio power cable from the radio to the vehicle's battery compartment, using accepted industry methods and standards. Be sure to grommet the firewall hole to protect the cable. Remove the 15-Amp (part number 6580283E06) or 20-Amp (part number 6580283E07) fuse from the fuseholder and connect the red lead of the radio power cable to the positive battery terminal using the hardware provided as shown in [Figure 2-12](#). Connect the black lead to a convenient solid chassis ground point. **DO NOT** connect the black lead directly to the battery's negative terminal.

NOTE: The nominal operating voltage of the radio is 13.2 VDC with an operating voltage range of 10.8 – 15.6 VDC.

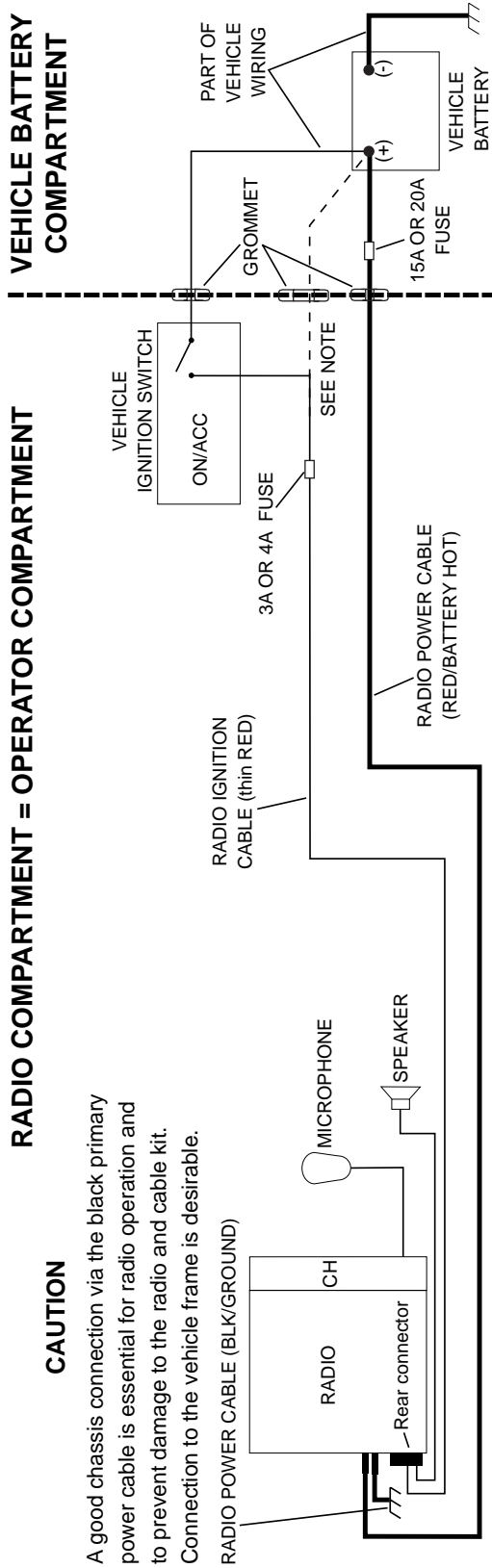

CAUTION

A good chassis connection via the black primary power cable is essential for radio operation and to prevent damage to the radio and cable kit. Connection to the vehicle frame is desirable.

NOTE:

Caution: if you choose to connect the radio's IGNITION line directly to the car's battery, excess use of the radio when the car's ignition is not running (i.e. alternator running) could result in a slow discharge of the car's battery. This configuration allows the radio to operate with the car's ignition switch ON or OFF.

If the radio's IGNITION line is wired to the car's ignition switch, the radio will only function when the car's ignition switch is turned ON.

Figure 2-11 Cabling Interconnect Diagram for Dash Mount

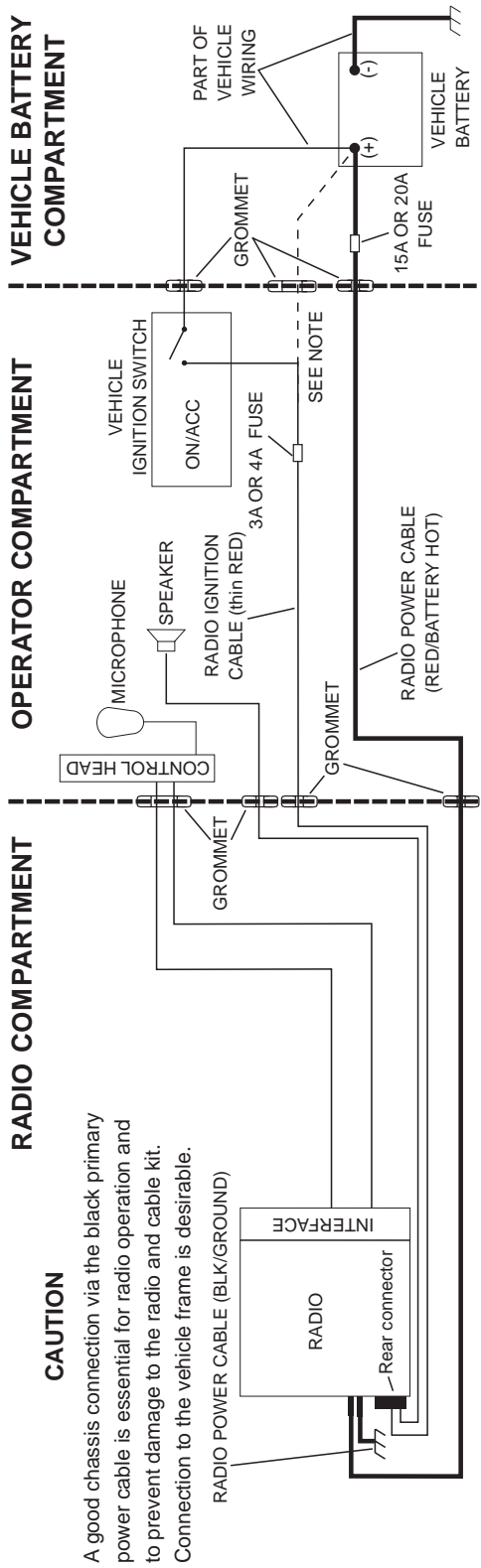

NOTE:
 Caution: if you choose to connect the radio's IGNITION line directly to the car's battery, excess use of the radio when the car's ignition is not running (i.e. alternator running) could result in a slow discharge of the car's battery. This configuration allows the radio to operate with the car's ignition switch ON or OFF.
 If the radio's IGNITION line is wired to the car's ignition switch, the radio will only function when the car's ignition switch is turned ON.

Figure 2-12 Cabling Interconnect Diagram for Remote Mount

2.4 Ignition Sense Cable

Motorola supplies an ignition sense cable and recommends that it be used with every *mobile* installation. The ignition sense cable allows the radio to be turned on and off with the vehicle ignition switch, and allows the radio to “remember” the state of the radio on/off switch, even if it is changed while the vehicle is off.

- For radio ON/OFF control independent of the ignition switch, connect the red ignition cable (pin 25 of accessory connector) to “battery hot” at the vehicle fuse block (dash mount only).
- For radio ON/OFF control via the ignition switch, connect the red ignition cable to “ignition” at the fuse block.

The ignition sense cable uses either a 3-Amp (P/N 6500139764) or 4-Amp (P/N 6580283E02) fuse.

For other considerations when connecting the ignition cable, see the MOTOTRBO DM 3400/DM 3401/DM 3600/DM 3601 Series Mobile Radios Basic Service Manual (Motorola publication number 6866575D33) or MOTOTRBO DM4400/DM4401/DM4600/DM4601 Series Mobile Basic Service Manual (Motorola publication number 68012003037).

2.5 Antenna Installation

IMPORTANT NOTE: To assure optimum performance and compliance with RF Energy Safety standards, these antenna installation guidelines and instructions are limited to metal-body vehicles with appropriate ground planes and take into account the potential exposure of back seat passengers and bystanders outside the vehicle.

NOTE: For mobile radios with rated power of 7 watts or less, the only installation restrictions are to use only Motorola approved antennas and install the antenna externally on metal body vehicles. For mobile radios with rated power greater than 7 watts, always adhere to all the guidelines and restrictions in [Section 2.5.1](#) below.

2.5.1 Selecting an Antenna Site/Location on a Metal Body Vehicle

1. **External Installation** – Check the requirements of the antenna supplier and install the vehicle antenna external to a metal body vehicle in accordance with those requirements.
2. **Roof Top** – For optimum performance and compliance with RF Energy Safety Standards, mount the antenna in the center of the roof.
3. **Trunk Lid** – On some vehicles with clearly defined, flat trunk lids, the antennas of some radio models (see restrictions below) can also be mounted on the center area of the trunk lid. For vehicles without clearly defined, flat trunk lids (such as hatchback autos, sport utility vehicles, and pick-up trucks), mount the antenna in the center of the roof.

BEFORE INSTALLING AN ANTENNA ON THE TRUNK LID,

– Be sure that the distance from the antenna location on the trunk lid will be at least 85 cm (33 inches) from the front surface of the rear seat-back to assure compliance with RF Energy Safety standards.

– Ensure that the trunk lid is grounded by connecting grounding straps between the trunk lid and the vehicle chassis.

NOTE: If these conditions cannot be satisfied, then mount the antenna on the roof top.

4. Ensure the antenna cable can be easily routed to the radio. Route the antenna cable as far away as possible from the vehicle electronic control units and associated wiring.
5. Check the antenna location for any electrical interference.

6. Make sure the mobile radio antenna is installed at least 30 cm (1 foot) away from any other antenna on the vehicle.
7. For MOTOTRBO DM Series Mobile Radio models with GPS using a GPS only or a combined RF/GPS antenna, ensure that the antenna has a clear view of the sky and that the antenna base with the GPS receiver is not covered by any metallic or radio frequency absorbing material. Any non-glass-mount GPS antenna should be positioned next to the RF antenna. Any other mobile radio antenna should be at least 30 cm (1 foot) away from the RF antenna.

NOTE: Any two metal pieces rubbing against each other (such as seat springs, shift levers, trunk and hood lids, exhaust pipes, etc.) in close proximity to the antenna can cause severe receiver interference.

2.5.2 Antenna Installation Procedure

1. Mount the antenna according to the instructions provided with the antenna kit. Run the coaxial cable to the radio mounting location. If necessary, cut off the excess cable and install the cable connector.
2. Connect the antenna cable connector to the radio antenna connector on the rear of the radio.
3. In case of a GPS model, connect the GPS antenna to the GPS antenna connector on the rear of the radio.

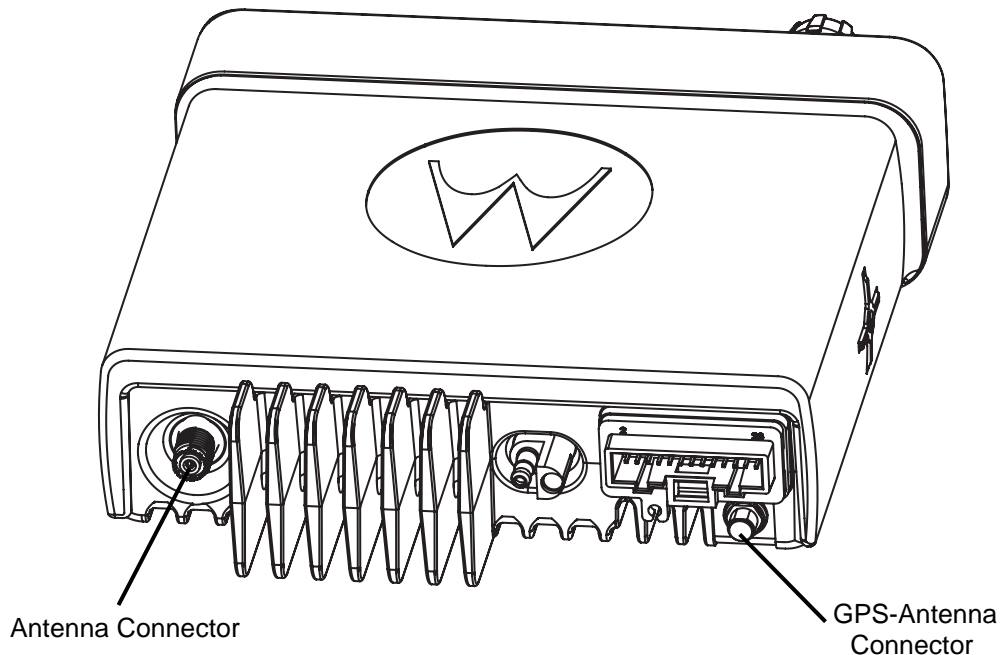

Figure 2-13 Antenna connections on the back of the radio

2.5.3 Antenna Connection

To ensure a secure connection of an antenna cable's BNC/Mini-U plug to a radio's BNC/Mini-U jack, their interlocking features must be properly engaged. If they are not properly engaged, the system will loosen.

Motorola recommends the following sequence to ensure proper attachment of the system (see [Figure 2-14](#)):

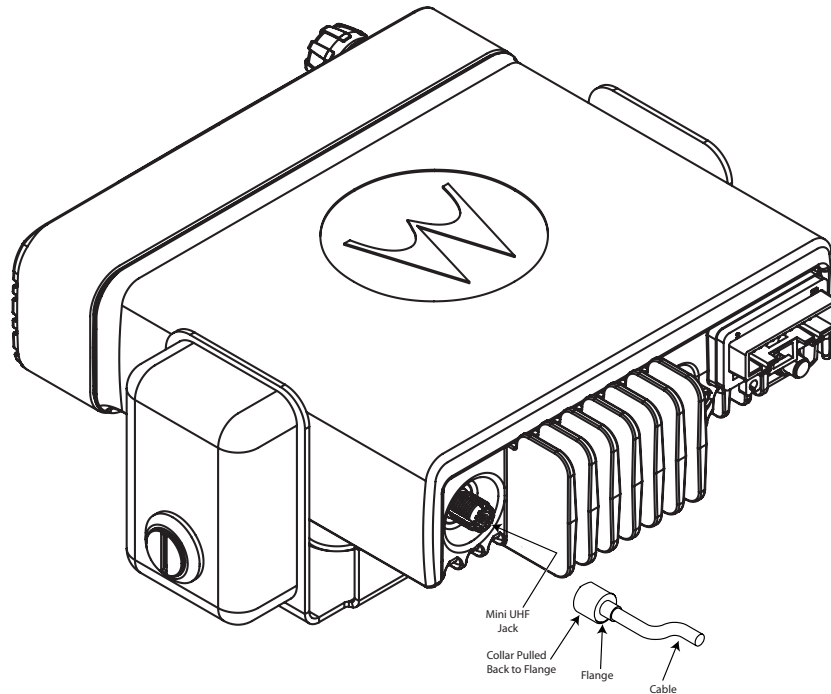

Figure 2-14 BNC/Mini-UHF Connection

1. Make sure that there is sufficient slack in the antenna cable.
2. Align the antenna cable plug's pin then firmly insert full into the radio jack. Turn it clockwise to tighten. It should take no more than a 1/4 turn.
3. Give a final tug, by hand, to the antenna cable plug.

NOTE: The BNC connection/Mini-UHF jack are in the same location. Forcing an improperly aligned antenna cable plug's pin into the radio jack can damage the connector and the radio.

2.6 Microphone Hang-Up Clip

2.6.1 Standard Hang-Up Clip

The hang-up clip must be within reach of the operator(s). Measure this distance before actually mounting the bracket. Since the bracket has a positive-detent action, the microphone can be mounted in any position. The microphone hang-up clip must be grounded.

Use the hang-up clip as a template to locate the mounting holes. To avoid interference when removing the microphone, install the flathead screw in the top clip hole.

2.7 Completing the Installation

Complete the installation by connecting the power wires and plugging in the microphone cable to the mobile.

Notes

Chapter 3 Options and Accessories Installation

3.1 Accessory Installation

The accessories must be installed through the rear accessory connector that is located on the rear of the radio, adjacent to the power connector. Most of the Motorola-approved accessories are supplied with female terminals crimped to a 20-gauge wire specifically designed to fit the plug of the rear accessory connector.

Insert the female terminal into the accessory connector assembly in the appropriate locations. The accessory connector assembly is provided together with the accessory. Connect the accessory connector assembly to the rear accessory connector on the back of the mobile. Do not use other generic terminals in the plug. Generic terminals can cause electrical intermittences and may cause damage to the plug.

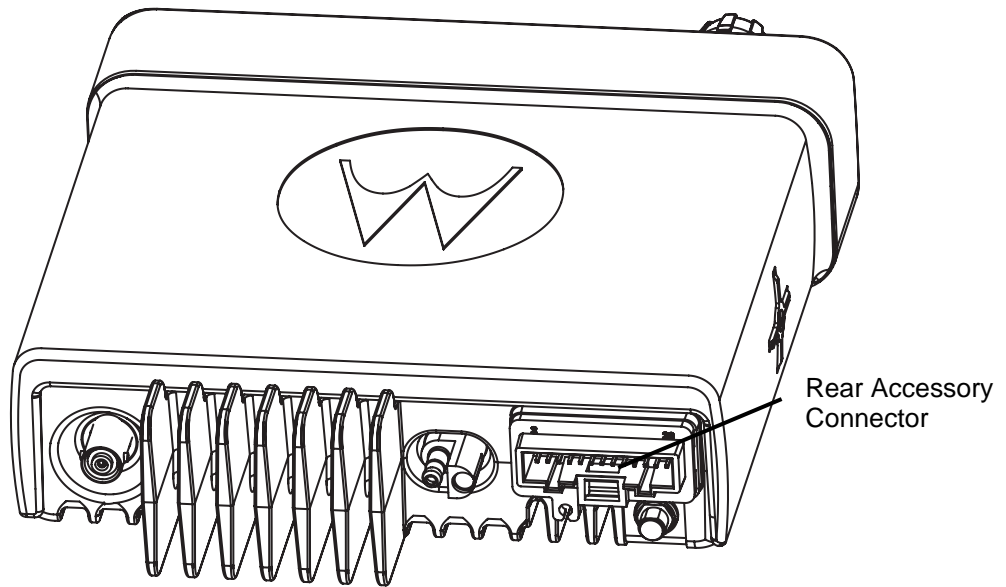

Figure 3-1 Location of the Rear Accessory Connector

Table 3-1 Rear Accessory Connector Pin Functions

Pin No.	Pin Name	Pin Function	Pin No.	Pin Name	Pin Function
1	USB+	USB + (Data)	14	Rx Audio	Receive Live Audio ²
2	USB-	USB - (Data)	15	AUX Audio 2	PUBLIC Address 2
3	VBUS	USB Power (5V from USB accessory/cable)	16	GND	Ground
4	USB/MAP_ID GND	USB/MAP_ID Ground	17	GP5-1 (PTT)	5V Level GPIO, PTT Input ¹
5	MAP_ID_2	Accessory Identifier	18	GND	Ground
6	MAP_ID_1	Accessory Identifier	19	GP5-2 (Monitor)	5V Level GPIO, Monitor Input ³
7	SW B+	Switched Battery Voltage	20	GP5-6	5V Level GPIO
8	PWRGND	Ground	21	GP5-3	5V Level GPIO, Channel Activity Function
9	SPKR-	Speaker - (3.2 ohm minimum impedance)	22	GP5-7	5V Level GPIO
10	SPKR+	Speaker + (3.2 ohm minimum impedance)	23	EMERGENCY	Emergency Switch Input
11	Tx Audio	Rear External Microphone Input ⁴	24	GP5-8	5V Level GPIO
12	Audio GND	Audio Ground	25	IGN SENSE	Ignition Sense ⁵
13	AUX Audio 1	PUBLIC Address 1	26	VIP-1	12V Tolerant, 5V GPIO, External Alarm

- ¹ Pulling this line to ground will activate PTT function, activating the AUX_MIC input.
- ² Fixed level (independent of volume level) received audio signal, including alert tones. Flat or de-emphasis are programmed by CPS. Output voltage is approximately 330 mVrms per 1 kHz of deviation.
- ³ This input is used to detect when a rear microphone accessory is taken off-hook, to override PL to alert the user to busy traffic prior to transmitting.
- ⁴ This microphone signal is independent of the microphone signal on the front microphone connector. The nominal input level is 80 mVrms for 60% deviation. The DC impedance is 660 ohms and the AC impedance is 560 ohms.
- ⁵ See [Figure 2-3](#) and [Figure 2-12](#) for wiring information.

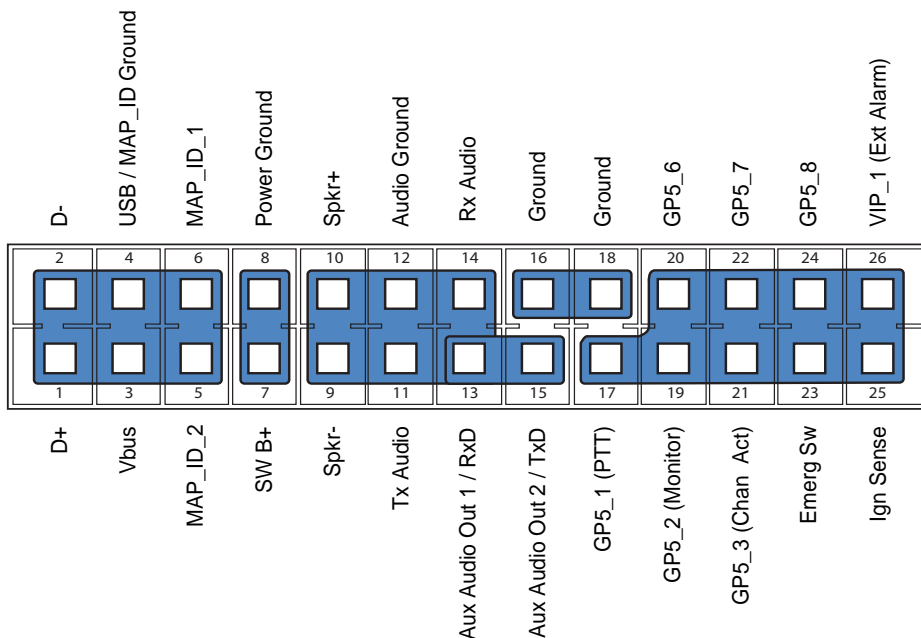

Figure 3-2 Pin Configuration of Rear Accessory Connector (as viewed from the rear of the radio)

3.1.1 Emergency Pushbutton or Footswitch Installation

Mount the emergency pushbutton (Motorola part number RLN5926A_) or the footswitch (Motorola part number RLN5929A_) using the hardware that comes with the kit. Press the terminal into the accessory connector housing. Connect the emergency switch wires to pins 23 and 18 (see Figure 3-3). Route the finished cable from the switch location to the control head location.

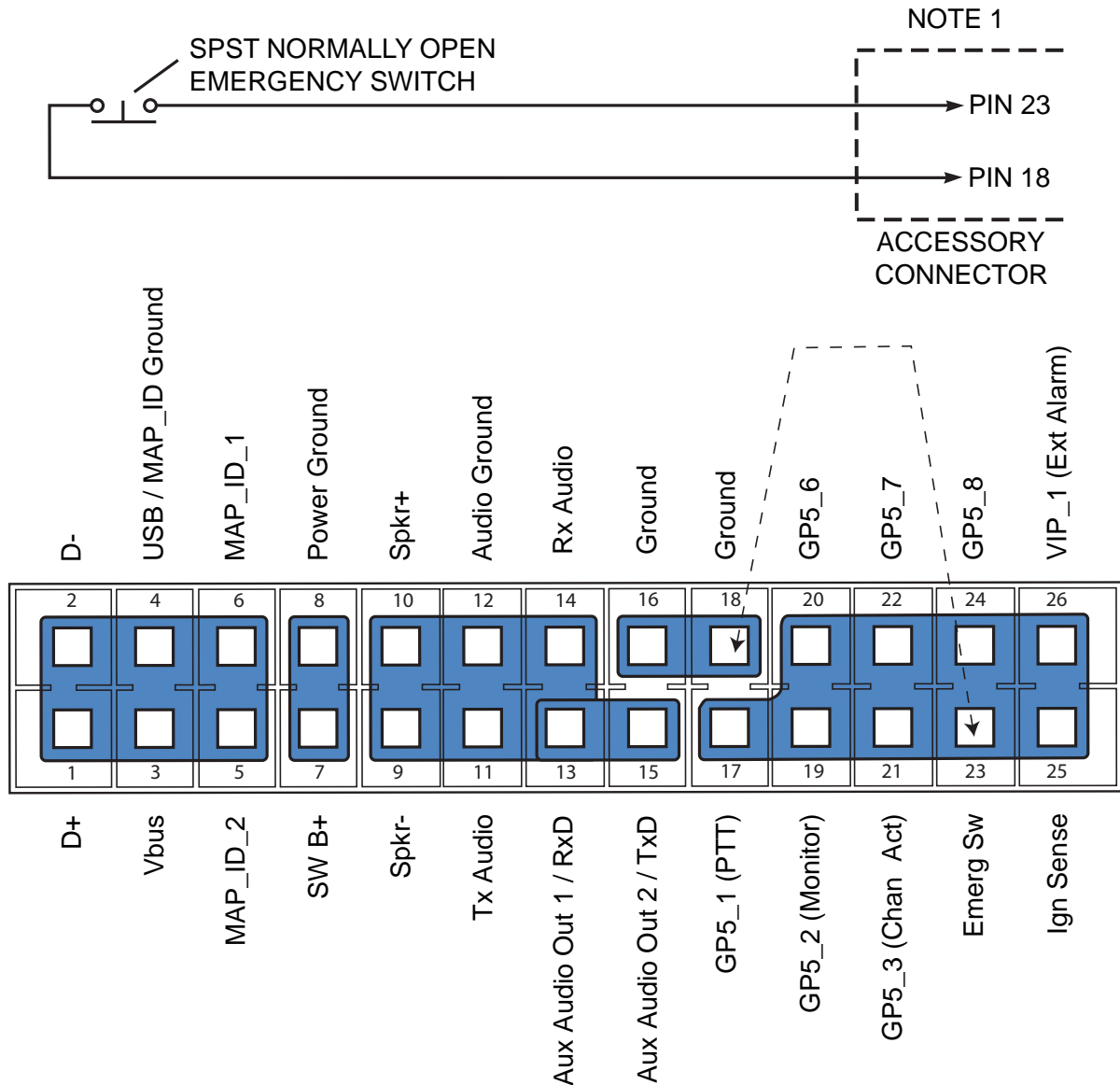

Figure 3-3 Emergency Switch Wiring Diagram

3.1.2 Horn and Lights (External Alarm) Relay

Allows the user to be alerted to an incoming call when away from the vehicle. The vehicle's horn or lights or both are used depending on which option is connected to the accessory port. When the radio receives a call alert or emergency alarm/call, there is a delay before activating the horn and/or lights. The delay is programmable using the Horn & Lights Delay Time feature in the CPS. Once activated, the Horn and/or Lights remain active depending on the option selected. The Horn & Lights feature can be toggled between ON or OFF, via a short or long programmable button press (Horn & Lights On/Off) or Horn/Lights (Utilities Menu) feature.

For installations that use the horn/lights option, select a suitable location for mounting (normally under the dash) and, referring to [Figure 3-4](#), perform the following procedure:

1. Horn Relay – Connect the relay contacts across the horn ring switch, typically found in the steering column. Connect the two control wires (female pins) into locations 26 and 18 of the connector.
2. Lights Relay – Connect the relay across the headlamp ON/OFF switch, typically found in the steering column. Connect the two control wires (female pins) into locations 26 and 18 of the accessory connector.

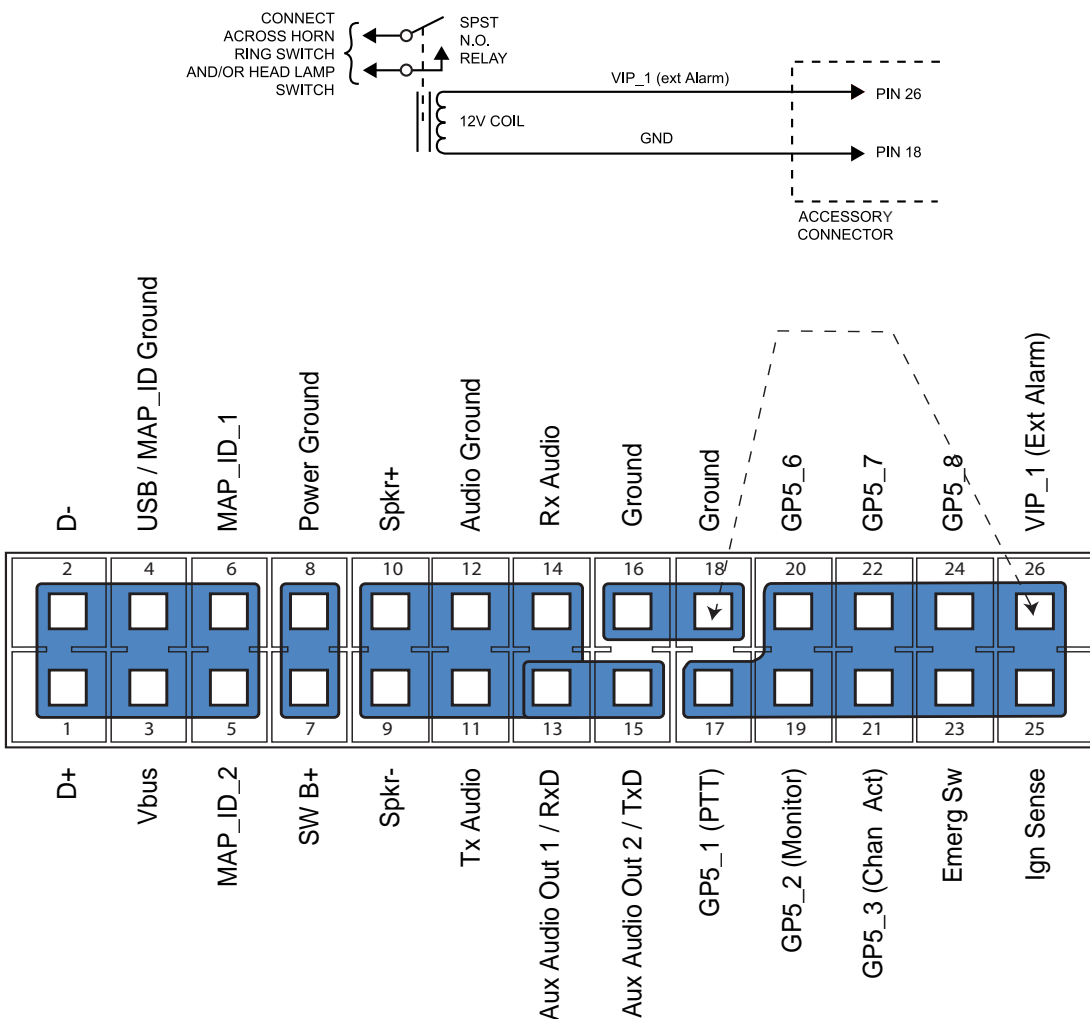



Figure 3-4 Horn and Lights Wiring Diagram

3.1.3 External Speaker

	<p>Caution</p> <p>DO NOT ground the radio's speaker leads. This system has a floating speaker output (dc voltage on both leads); damage to the audio circuit will result if either lead is grounded or if they are shorted together.</p>
---	---

The external speaker kit includes a trunion bracket that allows the speaker to be mounted in a variety of ways. With the trunion bracket, the external speaker can mount permanently on the dashboard or in accessible firewall areas. The trunion allows the external speaker to tilt for best operation. Mount the external speaker out of the way so that it will not be kicked or knocked around by the vehicle occupants. Mount the external speaker as follows:

1. Use the external speaker mounting bracket as a template to mark the mounting hole locations.
2. Use the self-drilling screws provided to fasten the trunion.
3. Attach the external speaker and fasten to the trunion with two wing screws.
4. Route the speaker wires under the carpet or floor covering, or behind the kick panels. Be sure the wires are out of the way and will not be snagged and broken by the occupants of the vehicle.

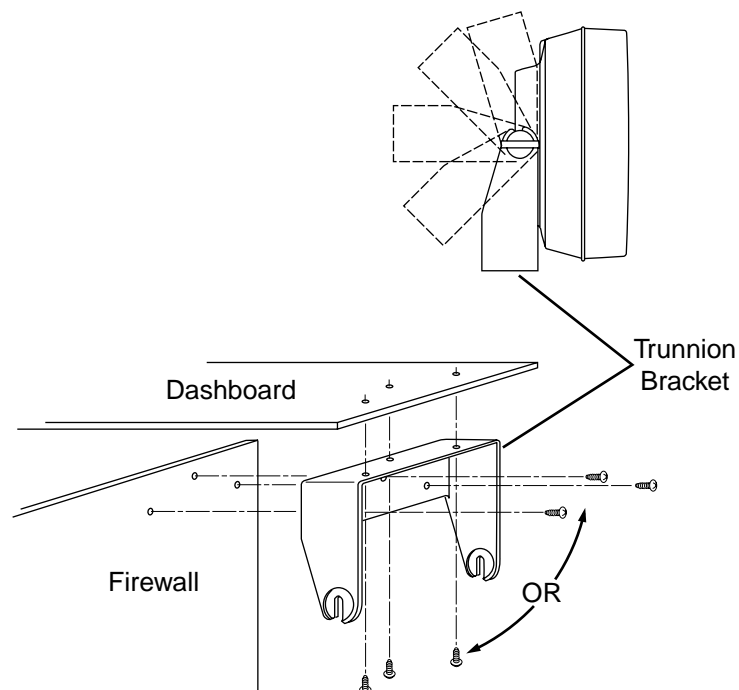

Figure 3-5 External Speaker Mounting

Notes

Chapter 4 Best Practices: Installation & Troubleshooting

In this section are Motorola recommended vehicle installation practices that can address or prevent many issues, including:

- Radio circuit damage due to over voltage condition
- Radio/Accessories "lock up"
- Radio/Accessories change state/lock-up when radio PTT is depressed
- Radio intermittently resets
- Alternator whine present when transmitting with engine running
- Radio/Accessories turn themselves on/off

4.1 Check Wiring of Ignition and Radio Ignition Sensing

- If it is required to turn the radio on and off via the ignition sense switch, in addition to the control head's on/off switch, connect the ignition sense lead to the accessory terminal from the ignition switch (usually in the vehicle's fuse panel under accessory or radio).

NOTE: Motorola recommends protecting or isolating the radio's ignition sense input from voltage spikes in excess of +/- 40 VDC. Such spikes can be hundreds of volts in amplitude and are common in larger vehicles (utility trucks, buses and etc.), especially when the source is common to a solenoid coil. A triggerable oscilloscope is required to determine the existence of such spikes as most voltmeters cannot measure in short duration (< 1 msec). If the condition of the intended ignition sense source is unknown, Motorola recommends isolating the source from the radio with a relay or the use of a suppression diode wired between the source and ground. Any high current suppression diode (i.e. MR2535) with a breakdown voltage of between 18 and 40 volts will suffice. A suitable diode kit is available from Motorola parts, kit number HLN6325_.

- If it is required to have the radio power up only via the control head's on/off switch, then connect the ignition sense lead directly to the positive terminal of the battery. This will mean the ignition sense will always be ignored and a re-wiring will be necessary in the future if the operator chooses any ignition sense CPS setting.
-

4.2 Check Physical Installation of Radio Ground and Radio Accessory Wiring

- Take care to scrape away paint on the chassis at the place where the ground connection is to be made, and try to keep the ground lead as short as possible.
- Verify that the A+ lead (red) is connected directly to the positive terminal of the battery and the ground lead (black) is connected to the vehicle's chassis using as short of a length of wire as is practical.
- For vehicles that have other types of electronic equipment installed (lights, flashers, computers siren/PA and etc.), use a separate ground for the mobile radio equipment.
- Make sure that the mobile radio antenna is the minimum required distance (three feet) from the mobile radio equipment to prevent radio frequency interference (RFI) from interfering with the radio and/or accessories.
- Do not coil up any excess length of the A+ (red) lead. Doing this may cause a large transient voltage to be produced when there is a high current drain (e.g. during transmit). This could cause the radio to reset when the push-to-talk (PTT) is depressed.
- Do not coil up any excessive length of antenna cable, if possible. It may affect the radio's receive performance.

4.3 Improve the Electrical Quality of the Power and Ignition Lines

- Use a relay to isolate the vehicle's ignition switch point (ACC) from the radio's ignition sense point. Control this relay from the vehicle's ignition switch point (ACC). Supply a cleaner voltage from the positive terminal of the battery into the relay, which will now be attached to the radio's ignition sense point. Now the ACC line toggles the relay, instead of directly toggling the radios ignition sense line.
 - Install a Power Line Filter between the A+ lead and the positive terminal of the battery. This is intended to filter the battery power applied to the transmitter power amplifiers. Pay extra caution to this because the series filter will introduce a negative spike when the radio transmits that may cause problems with radio operation.
 - For vehicles that use electromechanical relays to control external devices (lights, motors, switch boxes and etc.), these relay circuits should be isolated as best as possible from the mobile radio equipment. Also, diode suppression should be used across the relay contacts to minimize the noise produced by the collapsing magnetic field.
 - If the ignition sense switch is to be used, make sure that there is not a large voltage drop between the A+ point (usually the positive terminal of the battery) and the ignition sense point. In general, the voltage difference between these two points, should not be greater than 1.5 volts when all accessories/air-conditioner, etc. are turned on. Refer to the Basic Service Manual for specifications for minimum and maximum voltage levels. Typical battery voltage levels are 13.6V +/- 20%.
-

4.4 Jump-Start the Vehicle



Caution

Do not jump-start vehicle with radio power or ignition sense cables connected. Damage to the radio and/or accessories may result.

The state of your radio prior to needing a jump-start may be unknown, and the radio may attempt to return to its last state (radio ON), when doing a jump-start. Therefore, Motorola recommends the following steps be taken before jump-starting any vehicle containing a radio.

1. Locate the ignition sense line and the main power leads (thick red wire) near the battery positive terminal.

NOTE: These lines are fused. In the event these lines are not fused (add the appropriate fuse in line) use whatever tools necessary to physically disconnect the ignition sense and power lines from the battery terminal.

2. Open up the fuse holders and remove the fuses out of the kits.
3. Re-tighten the fuse holders but without the fuses to insure that ignition sense and power lines do not interfere with any moving parts.
4. Proceed with the jump-start routine as described by your vehicle owner's manual.
5. Once the jump-start process is complete, re-install the fuses into their holders.

4.5 Eliminate Noise/Howling from PA Speaker

1. Refer to [Section 2.1.2](#) for recommended methods of installation available for the mobile two-way radio, with accessories placed to the vehicle as desired.
2. Refer to [Figure 2-3](#) and [Figure 2-4](#) for the wiring diagrams for the recommended configurations.

Notes

Appendix A EMEA Regional Warranty, Service and Technical Support

A.1 Warranty and Service Support

Motorola offers long term support for its products. This support includes full exchange and/or repair of the product during the warranty period, and service/ repair or spare parts support out of warranty. Any "return for exchange" or "return for repair" by an authorized Motorola Dealer must be accompanied by a Warranty Claim Form. Warranty Claim Forms are obtained by contacting an Authorized Motorola Dealer.

A.1.1 Warranty Period and Return Instructions

The terms and conditions of warranty are defined fully in the Motorola Dealer or Distributor or Reseller contract. These conditions may change from time to time and the following notes are for guidance purposes only.

In instances where the product is covered under a "return for replacement" or "return for repair" warranty, a check of the product should be performed prior to shipping the unit back to Motorola. This is to ensure that the product has been correctly programmed or has not been subjected to damage outside the terms of the warranty.

Prior to shipping any radio back to the appropriate Motorola warranty depot, please contact Customer Resources (Please see page A-3). All returns must be accompanied by a Warranty Claim Form, available from your Customer Services representative. Products should be shipped back in the original packaging, or correctly packaged to ensure no damage occurs in transit.

A.1.2 After Warranty Period

After the Warranty period, Motorola continues to support its products in two ways.

1. Motorola's Managed Technical Services (MTS) offers a repair service to both end users and dealers at competitive prices.
2. MTS supplies individual parts and modules that can be purchased by dealers who are technically capable of performing fault analysis and repair.

A.2 European Radio Support Centre (ERSC)

The ERSC Customer Information Desk is available through the following service numbers:

Austria:	08 00 29 75 41	Italy:	80 08 77 387
Belgium:	08 00 72 471	Luxemburg:	08 00 23 27
Denmark:	80 88 58 80	Netherlands:	08 00 22 45 13
Finland:	08 00 11 49 910	Norway:	80 01 11 15
France:	08 00 90 30 90	Portugal:	08 00 84 95 70
Germany:	08 00 18 75 240	Spain:	90 09 84 902
Greece:	00 80 04 91 29 020	Sweden:	02 07 94 307
UK:	08 00 96 90 95	Switzerland:	08 00 55 30 82
Ireland:	18 00 55 50 21	Iceland:	80 08 147

Or dial the European Repair and Service Centre:

Telephone: +49 30 6686 1555

Fax ERSC: + 49 30 6686 1579

Email ERSC: ERSC@motorolasolutions.com

Please use these numbers for repair enquiries only.

A.3 Piece Parts

Some replacement parts, spare parts, and/or product information can be ordered directly.

If a complete Motorola part number is assigned to the part, it is available from Motorola Radio Products and Solutions Organization (RPSO). If no part number is assigned, the part is not normally available from Motorola. If the part number is appended with an asterisk, the part is serviceable by Motorola Depot only. If a parts list is not included, this generally means that no user-serviceable parts are available for that kit or assembly.

Orders for replacement parts, kits and assemblies should be placed directly on Motorola's local distribution/dealer organisation or via Motorola Online at:

<https://emeaonline.motorola.com/Login.aspx>

* The Radio Products and Solutions Organization (RPSO) was formerly known as the Radio Products Services Division (RPSD) and/or the Accessories and Aftermarket Division (AAD).

A.4 Technical Support

Motorola Product Services is available to assist the dealer/distributors in resolving any malfunctions which may be encountered.

Russia and Armenia – Andrey Nagornykh
Telephone: +7 495 787 8910
Fax: +7 495 785 0185
Email: mwcb47@motorolasolutions.com

Middle East and Africa – Wayne Holmes
Telephone: +49 (0) 6126 957 6237
Fax: +49 (0) 6126 957 6826
Email: wayne.holmes@motorolasolutions.com

France – Armand Roy
Telephone: +33 1 6935 7868
Fax: +33 1 6935 7808
Email: armand.roy@motorolasolutions.com

France – Laurent Irrmann
Telephone: +33 1 6935 7866
Fax: +33 1 6935 7808
Email: laurent.irrmann@motorolasolutions.com

Central and East Europe – Siggy Punzenberger
Telephone: +49 (0) 6128 70 2342
Fax: +49 (0) 6128 95 1096
Email: TFG003@motorolasolutions.com

Germany – Customer Connect Team
Telephone: +49 (0) 30 6686 1539
Fax: +49 (0) 30 6686 1916
Email: ESSC@motorolasolutions.com

Italy – Ugo Gentile
Telephone: +39 02 5220 7825
Fax: +39 02 5220 7810
Email: Ugo.Gentile@motorolasolutions.com

A.5 Further Assistance From Motorola

You can also contact the Customer Help Desk through the following web address:
http://www.motorola.com/Business/US-EN/Government/Contact_Us

Notes

Index

A

- accessories
 - installing
 - dash mount3-1
- antenna
 - cable, see Cables, antenna
 - connection2-13
 - diagrams2-13
 - installing2-11
 - mounting2-11

B

- base stations1-5
- black lead2-8

C

- cables
 - antenna2-4
 - connection4-1
 - diagrams2-2, 2-9, 2-10, 2-13
 - ignition2-11
 - ignition sense2-11
 - power2-8
- configurations
 - dash mount1-4
- control head
 - dash mount1-4
 - see also specific model names
- control stations1-5

D

- dash mount
 - accessories installations3-1
 - configuration1-4
 - installation2-2, 2-3
 - radio dimensions1-1
 - trunnion2-5

E

- emergency footswitch3-3
- emergency pushbutton3-3

F

- footswitch, emergency3-3

H

- horn relay3-4

I

- ignition
 - cable2-11
- installation
 - examples2-1

J

- J2
 - pin configuration2-2

L

- leads
 - black2-8
 - light relay3-4
- locking kit, installing2-6

M

- microphone
 - hang-up clip, standard2-13
 - S-hook2-5
- mounting configurations2-4
 - dash1-4, 2-5

O

- ordering replacement partsA-1

P

- parts, ordering replacementA-1
- pin
 - functions3-2
 - removal tool2-1
- pin configurations
 - J22-2
- pushbutton, emergency3-3

R

- rear accessory jack, see J2
- relays
 - horn3-4
 - light3-4
- replacement parts, orderingA-1

S

- speaker
 - connecting2-13
 - mounting3-5

T

- tools, required2-1
- trunnion

Index-2

bracket for speaker 3-5
dash mount 2-5
locking kit 2-6
mounting bracket 2-5
orientation 2-4
transmission hump mounting 2-5

W

wiring diagrams 2-2